

Chapter 1

Introduction to Intelligent Robotics

On successful completion of this course, students will be able to:

- Explain history and definition of robot.
- Describe types of robot.
- Explain the newest technology of intelligent robotics.
- Explain the concept of embedded system for robotics.

Introduction

Robotics technology increase drastically following the demand of intelligent robotics that able to help human kind. For robots to be intelligent in the way people are intelligent, they will have to learn about their world, and their own ability to interact with it, much like people do. Robot vision is a branch of robotics that learns about acquisition and image processing for intelligent robotics. At 2030, it is predicted that almost home duty task accomplished by service robot that use vision sensors such as camera, it is a big challenge for us to develop that robot. A robot is a mechanical or virtual agent, usually an electro-mechanical machine that is guided by a computer program or electronic circuitry. Intelligent robotics is a system that contains sensors, camera, control systems, manipulators, power supplies and software all working together to perform a task. That's why the ability to develop intelligent robotics using computer vision is a must to for the future.

History of Robot

The term Artificial Intelligence or AI stirs emotions. In 1955, John McCarthy, one of the pioneers of AI, was the first to define the term Artificial intelligence, roughly as follows:

The goal of AI is to develop machines that behave as though they were intelligent.

According to McCarthy's definition the aforementioned robots can be described as intelligent. The word of robot is very familiar with us today [1]. The term robot was first used to denote fictional automata in a 1921 play R.U.R. Rossum's Universal Robots by the Czech writer, Karel Čapek. According to Čapek, the word was created by his brother, Josef from the Czech "robot",

meaning servitude. In 1927, Fritz Lang's *Metropolis* was released; the *Maschinenmensch* ("machine-human"), a gynoid humanoid robot, also called "Parody", "Robotrix", or the "Maria impersonator" (played by German actress Brigitte Helm), was the first robot ever to be depicted on film [2].

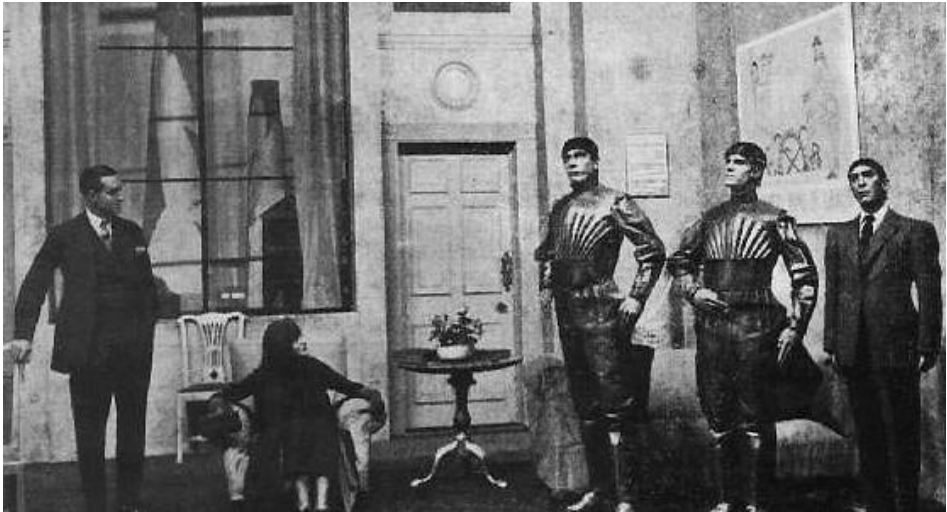

Figure 1.1 R.U.R by Czech Writer [2].

The history of robots has its origins in the ancient world. The modern concept began to be developed with the onset of the industrial revolution which allowed for the use of complex mechanics and the subsequent introduction of electricity. This made it possible to power machines with small compact motors. In the early 20th century, the modern formulation of a humanoid robot was developed. Today, it is now possible to envisage human sized robots with the capacity for near human thoughts and movement.

At ~270BC an ancient Greek engineer named Ctesibus made organs and water clocks with movable figures. Al-Jazari (1136–1206), a Muslim inventor during the Artuqid dynasty, designed and constructed a number of automatic machines, including kitchen appliances, musical automata powered by water, and the first programmable humanoid robot in 1206. Al-Jazari's robot was a boat with four automatic musicians that floated on a lake to entertain guests at royal drinking parties. His mechanism had a programmable drum machine with pegs (cams) that bump into little levers that operate the percussion. The drummer could be made to play different rhythms and different drum patterns by moving the pegs to different locations.



Figure 1.2 Al-Jazari's toy boat, musical automata. The first humanoid robot claimed in the world.

In Japan, complex animal and human automata were built between the 17th to 19th centuries, with many described in the 18th century *Karakuri zui*. One such automaton was the *karakuri ningyō*, a mechanized puppet.

Modern Robot glory starts from 1970, when Professor Victor Scheinman at Stanford University designed the standard manipulator. Currently, the standard kinematics configuration known as robotic arms is still used. Finally, in 2000 Honda showed off a robot that was built many years named ASIMO, and is followed by Sony AIBO robot dog.



Figure 1.3 Karakuri, robot from Japan.

Table 1.1 *The timeline of robotics development.*

No.	Year	Description
1	1495	Around 1495 Leonardo da Vinci sketched plans for a humanoid robot.
2	1920	Karel Capek coins the word 'robot' to describe machines that resemble humans in his play called Rossums Universal Robots. The play was about a society that became enslaved by the robots that once served them.
3	1937	Alan Turing releases his paper "On Computable Numbers" which begins the computer revolution.
4	1997	On May 11, a computer built by IBM known as Deep Blue beat world chess champion Garry Kasparov.
5	1999	Sony releases the first version of AIBO, a robotic dog with the ability to learn, entertain and communicate with its owner. More advanced versions have followed.
6	2000	Honda debuts ASIMO, the next generation in its series of humanoid robots.
7	2008	After being first introduced in 2002, the popular Roomba robotic vacuum cleaner has sold over 2.5 million units, proving that there is a strong demand for this type of domestic robotic technology.
8	2011	The first service robot from Indonesia named Srikandi III with the stereo vision system and multiple obstacles avoidance ability developed at ITS Surabaya.
9	2013	Intelligent telepresence robot developed at BINUS University from collaboration of NUNI.
10	2014	Vision based grasping model for Manipulator developed at BINUS University - Jakarta.

Types of Robot

Robot designed to fulfill user needs. Robot types can be divided into:

- Manipulator robot, for example an arm robot.
- Wheeled robot.
- Walking robot.
- Humanoid robot.
- Aerial robot.

- Submarine robot.

A robot has these essential characteristics:

- 1) *Sensing*, First of all your robot would have to be able to sense its surroundings. It would do this in ways that are not unsimilar to the way that you sense your surroundings. Giving your robot sensors: light sensors (eyes), touch and pressure sensors (hands), chemical sensors (nose), hearing and sonar sensors (ears), and taste sensors (tongue) will give your robot awareness of its environment.
- 2) *Movement*, A robot needs to be able to move around its environment. Whether rolling on wheels, walking on legs or propelling by thrusters a robot needs to be able to move. To count as a robot either the whole robot moves, like the Sojourner or just parts of the robot moves, like the Canada Arm.
- 3) *Energy*, A robot needs to be able to power itself. A robot might be solar powered, electrically powered, battery powered. The way your robot gets its energy will depend on what your robot needs to do.
- 4) *Programmability*, it can be programmed to accomplish a large variety of tasks. After being programmed, it operates automatically.
- 5) *Mechanical capability*, Enabling it to act on its environment rather than merely function as a data processing or computational device (a robot is a machine).
- 6) *Intelligence*, A robot needs to be smart. This is where programming enters the pictures. A programmer is the person who gives the robot its 'smarts.' The robot will have to have some way to receive the program so that it knows what it is to do.

A manipulator is a device used to manipulate materials without direct contact. The applications were originally for dealing with radioactive or biohazardous materials, using robotic arms, or they were used in inaccessible places. In more recent developments they have been used in applications such as robotically-assisted surgery and in space. It is an arm-like mechanism that consists of a series of segments, usually sliding or jointed, which grasp and move objects with a number of degrees of freedom.

Robot manipulators are created from a sequence of link and joint combinations. The links are the rigid members connecting the joints, or axes. The axes are the movable components of the robotic manipulator that cause relative motion between adjoining links. The mechanical joints used to

construct the robotic arm manipulator consist of five principal types. Two of the joints are linear, in which the relative motion between adjacent links is non-rotational, and three are rotary types, in which the relative motion involves rotation between links.

The arm-and-body section of robotic manipulators is based on one of four configurations. Each of these anatomies provides a different work envelope and is suited for different applications.

- 1) Gantry - These robots have linear joints and are mounted overhead. They are also called Cartesian and rectilinear robots.
- 2) Cylindrical - Named for the shape of its work envelope, cylindrical anatomy robots are fashioned from linear joints that connect to a rotary base joint.
- 3) Polar - The base joint of a polar robot allows for twisting and the joints are a combination of rotary and linear types. The work space created by this configuration is spherical.
- 4) Jointed-Arm - This is the most popular industrial robotic configuration. The arm connects with a twisting joint, and the links within it are connected with rotary joints. It is also called an articulated robot [3].

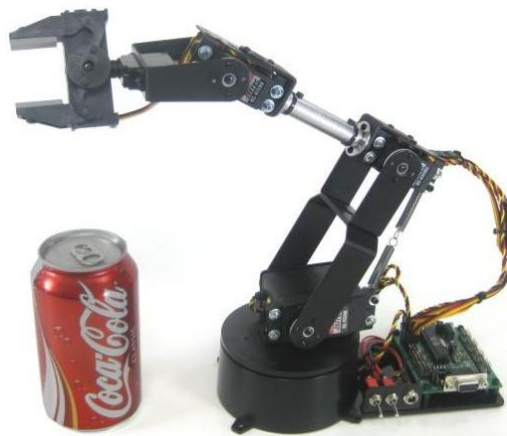

Figure 1.4 4 DOF Manipulator / arm robot from Lynxmotion suitable for education (source: lynxmotion.com).

As the development of robot technology, the capability of the robot to "see" or vision based robot has been developed such as ASIMO, a humanoid robot created by Honda. With a height of 130 centimeters and weighs 54 kilograms,

the robot resembles the appearance of an astronaut with the ability fingers capable to handling egg. ASIMO can walk on two legs with a gait that resembles a human to a speed of 6 km / h. ASIMO was created at Honda's Research and Development Center in Wako Fundamental Technical Research Center in Japan. The model is now the eleventh version, since the commencement of the ASIMO project in 1986. According to Honda, ASIMO is an acronym for "Advanced Step in Innovative Mobility" (a big step in the innovative movement). This robot has a height of 130cm with a total of 34 DOF and use 51.8V LI-ION rechargeable and the ability and mechanical grip better.



Figure 1.5 ASIMO Robot [4].

The rapid development of robot technology has demanded the presence of intelligent robots capable of complement and assisted the work of man. The ability to develop robots capable of interacting today is very important, for example, the development of educational robot NAO from France and Darwin OP from Korea. In the latest development of robot vision are generally

humanoid form, requires the Linux embedded module that can process images from the camera quickly. For example, Smart Humanoid robot package Ver. 2.0 for general-purpose robot soccer or created by authors who have the specification:

- CM-530 (Main Controller-ARM Cortex (32bits) with AX-12A (Robot Exclusive Actuator, Dynamixel).
- AX-18A (Robot Exclusive Actuator, Dynamixel).
- Gyro Sensor (2 Axis) dan Distance measurement system.
- RC-100A (Remote Controller).
- Rechargeable Battery (11V, Li-Po, 1000mA/PCM).
- Balance Battery Charger.
- Humanoid Aluminum frame full set.
- Gripper frame set.
- 1.7GHz Quad core ARM Cortex-A9 MPCore.
- 2GB Memory with Linux UBuntu.
- 6 x High speed USB2.0 Host port.
- 10/100Mbps Ethernet with RJ-45 LAN Jack.



Figure 1.6 Smart Humanoid ver 2.0 using embedded system and webcam based on LINUX Ubuntu.

Embedded Systems for Robot

The robotics system requires adequate processor capabilities such as the ability of the processor speed, memory and I / O facilities. The figure below is a block diagram of an intelligent robotics that can be built by beginners.

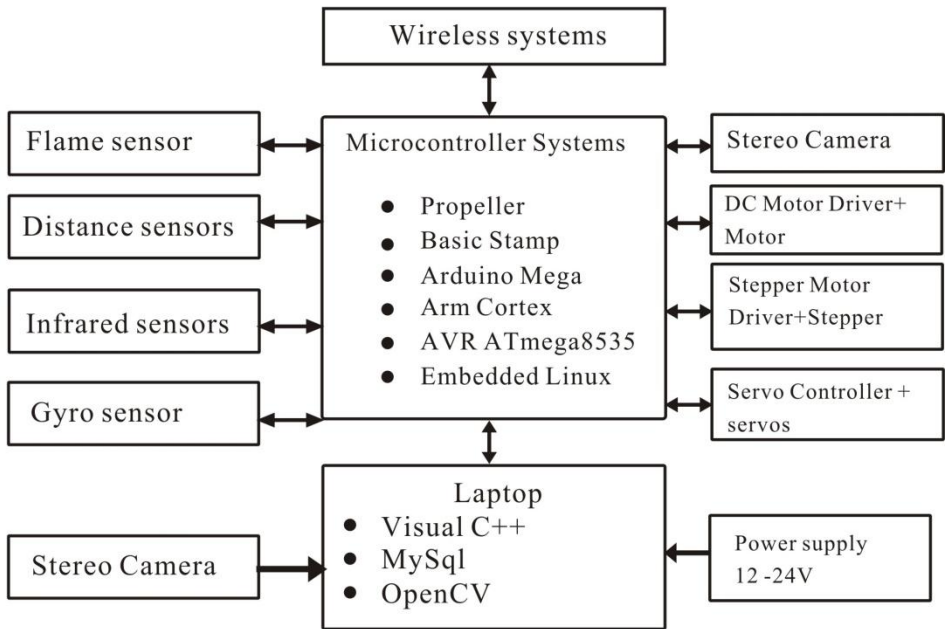

Figure 1.7 Embedded system for intelligent robotics.

From the picture above, the point is you can use a variety of microprocessor / microcontroller to make the robot as smart as possible. You may use the standard minimum systems such as Propeller, AVR, Basic Stamp, and Arm Cortex with extraordinary abilities. All inputs are received by the sensors will be processed by the microcontroller. Then through the programs that we have made microprocessor / microcontroller will take action to the actuator such as a robot arm and the robot legs or wheels. Wireless technology used for the purposes of the above if the robot can transmit data or receive commands remotely. While the PC / Laptop is used to program and perform computational processes data / images with high speed, because it is not able to be done by a standard microcontroller. To provide power supply to the robots, we can use dry battery or solar cell. For the purposes of the experiment, can be used as a

standard microcontroller for main robot controller as shown below using Arduino Mega:

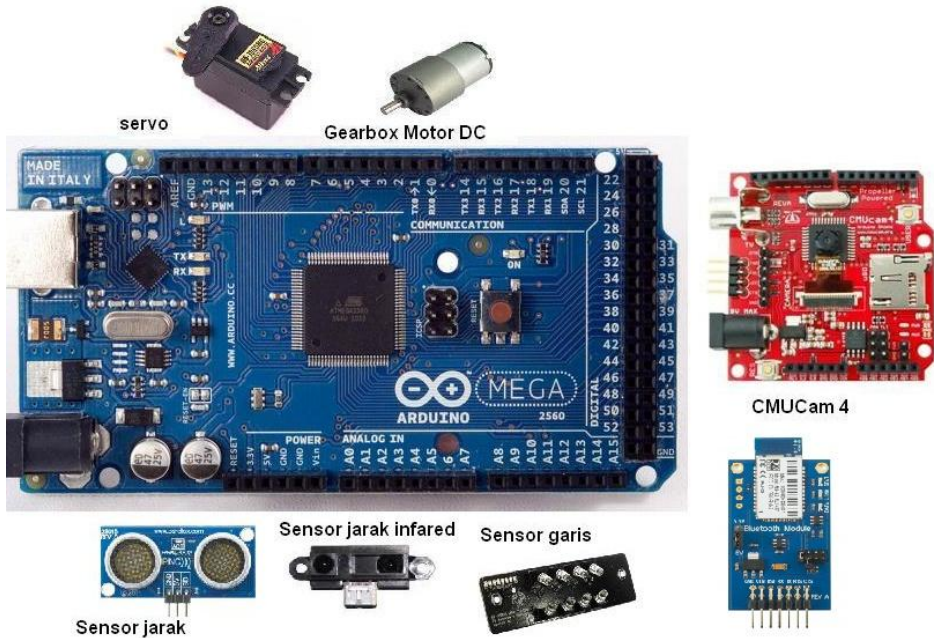

Figure 1.8 Single chip solution for robot using Arduino Mega.

The figure shows that the standard microcontroller technologies such as AVR, Arduino or Propeller and Arm Cortex, can be used as the main controller of mobile robots. Technology sensors and actuators can be handled well using a microcontroller with I2C capability for data communication between the microcontrollers with a serial devices others. Some considerations in choosing the right microcontroller for the robot is the number of I / O, ADC capability, and signal processing features, RAM and Flash program memory. In a complex robot that requires a variety of sensors and large input the number, often takes more than one controller, which uses the principle of master and slave. In this model there is a 1 piece main controller which functions to coordinate the slave microcontroller.

In general, to drive the robots there are several techniques such as:

- Single wheel drive, which is only one front wheel that can move to the right and to the left of the steering.

- Differential drive, where 2 wheels at the back to adjust the direction of motion of the robot.
- Synchronous drive, which can drive a 3 wheeled robot.
- Pivot drive, It is composed of a four wheeled chassis and a platform that can be raised or lowered. The wheels are driven by a motor for translation motion in a straight line.
- Tracked robot uses wheels tank.

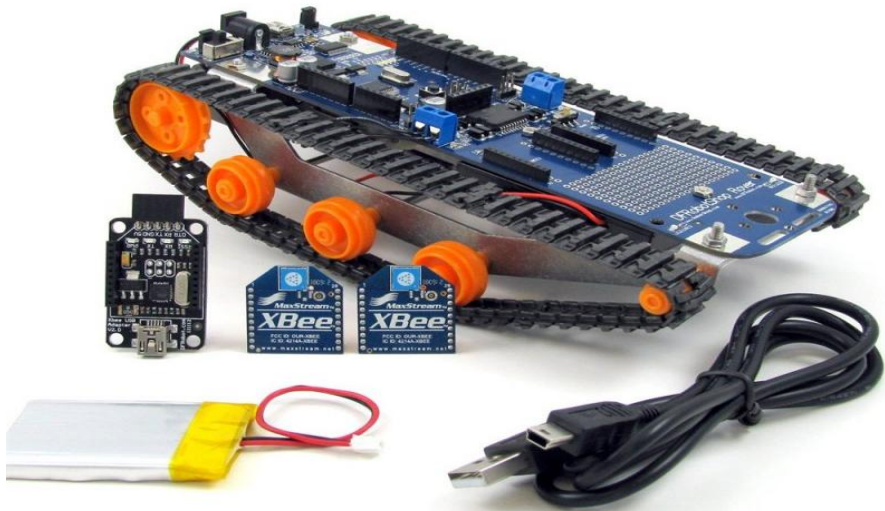

Figure 1.10 Tank Robot DFRobot Rover ver.2 using Arduino and XBee for Wireless Communication (source:robotshop.com).

- Ackerman steering, where the motion of the robot is controlled by the 2 front wheels and 2 rear wheels.
- Omni directional drives, where the motion of the robot can be controlled 3 or 4 wheel system that can rotate in any direction, so that the orientation of the robot remains. Omniwheel useful because the orientation of the robot is fix with the standard wheel angle $\alpha_1 = 0^\circ, \alpha_2 = 120^\circ$ and $\alpha_3 = 240^\circ$. Global frame $[x, y]$ represents robot's environment and the location of robot can be represented as (x, y, θ) . The global velocity of robot can be represented as $\dot{x}, \dot{y}, \dot{\theta}$.

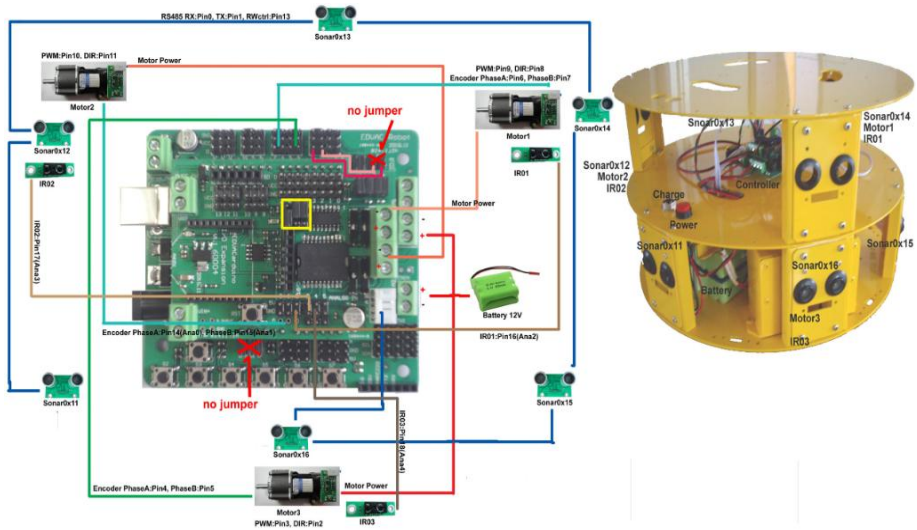

Figure 1.11 Mobile Robot with omni directional drive systems (source: nexusrobot.com).

Robot Vision

There are several important terms in the robot vision interconnected, including computer vision, machine vision and robot vision. Computer vision is the most important technology in the future in the development of interactive robots. Computer Vision is a field of knowledge that focuses on the field of artificial intelligence and systems associated with acquisition and image processing. Machine vision is implemented process technology for image - based automatic inspection, process control, and guiding robots in various industrial and domestic applications. Robot vision is the knowledge about the application of computer vision in the robot. The robot needs vision information to decide what action is to be performed. The application is currently in robot vision are as robot navigation aids, search for the desired object, and other environmental inspection. Vision on the robot becomes very important because it received more detailed information than just the proximity sensor or other sensors. For example, the robot is able to recognize whether the detected object is a person's face or not. Furthermore, an advanced vision system on the robot makes the robot can distinguish a face accurately (Face recognition system using PCA method, LDA and others) [6] [10]. The processing of the input image from the camera to have meaning for the robots known as visual perception, starting from image acquisition, image preprocessing to obtain the

desired image and noise-free, for example, feature extraction to interpretation as shown in Figure 1.12. For example, for customer identification and avoidance of multiple moving obstacles based vision, or to drive the servo actuator to steer the camera as it leads to a face (face tracking) [4].

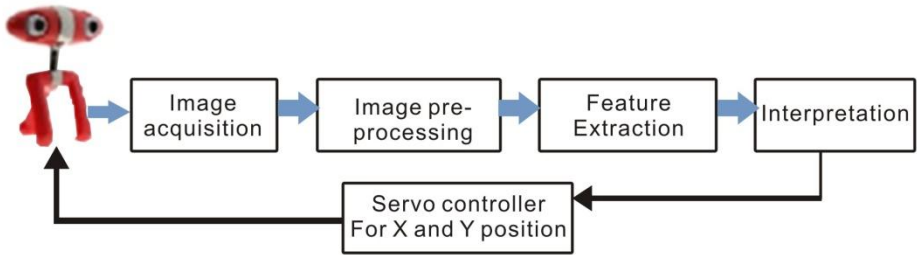

Figure 1.12 Perception model for a stereo vision [11].

An example of intelligent robotics is a humanoid robot HOAP-1 with stereo vision for navigation system. HOAP-1 is a commercial humanoid robot from Fujitsu Automation Ltd. and Fujitsu Laboratories Ltd. for behavior research. In the vision sub-system of HOAP-1, the depth map generator calculate depth map image from stereo images. The path planning sub-system generate a path from the current position to the given goal position while avoid obstacles.

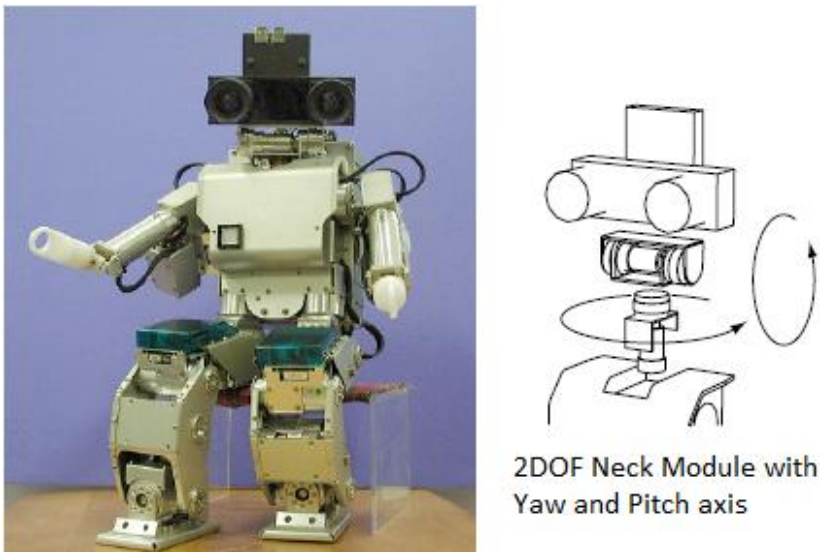

Figure 1.13 Example of Vision-based Navigation system for Humanoid robot HOAP-1 [12].

Another example is a telepresence robot developed by author as shown in figure 1.14. The test was conducted by running Microsoft IIS and Google Application Engine on the laptop. When the servers were ready, Master Controller, implemented by using a laptop, opened the application through web browser that support WebRTC and entered 192.168.1.101 which was the address of both servers to open it. This is not a problem because the servers were running on different ports. After the connections were established, Master controller then received image and sound stream from the robot and sent back image and sound from Master Controller web camera to the robot. Experiments of intelligent telepresence robot had been tested by navigating the robot to staff person and to avoid obstacles in the office. Face tracking and recognition based on eigenspaces with 3 images every person had been used and a databases of the images had been developed. The robot was controlled using integrated web application (ASP.Net and WebRTC) from Master Control. With a high speed Internet connection, simulated using wireless router that had speed around 1 Mbps, the result of video conferencing was noticeable smooth.

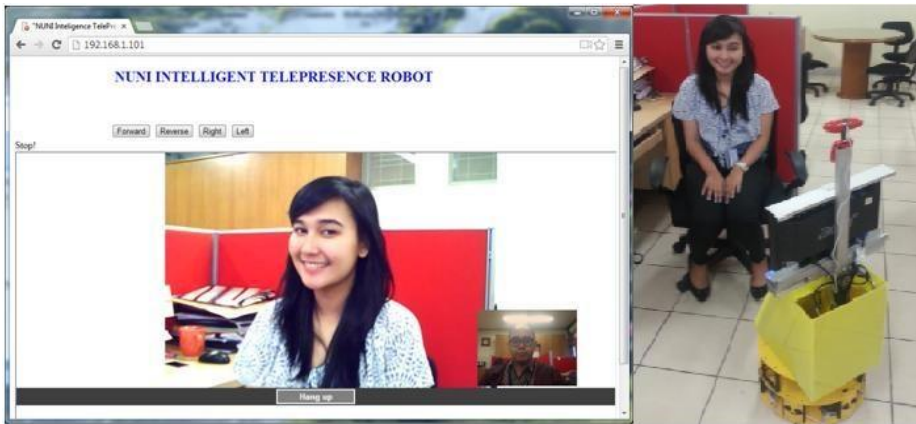

Figure 1.14 Intelligent Telepresence robot using omniwheel and controlled using Web [11].

Images collected by a robot during the embodied object recognition scenario often capture objects from a non- standard viewpoint, scale, or orientation. In subsequent development, artificial intelligence for the robot to recognize and understand the human voice, attentive to the various motion listener and able to provide a natural response by the robot are challenge ahead to build future robots.

Exercises

- 1) Explain the history of robots.
- 2) Explain the roles of computer vision in robotics.
- 3) Describe types of drive systems for robot.
- 4) Develop a block diagram of tank robot using embedded system.
- 5) Find out the advantages of stereo vision.

References

- [1] E. Wolfgang, Introduction to Artificial Intelligence, Springer Publisher, 2011.
- [2] www.wikipedia.org.
- [3] <http://www.galileo.org/robotics/intro.html>.
- [4] Asimo.honda.com.
- [5] Budiharto W., Santoso A., Purwanto D., Jazidie A., Multiple moving obstacles for service robot using Stereo Vision, *Telkomnika Journal*, Vol. 9 no.3, 2011.
- [6] M. Spong, Hutchinson & Vidyasagar, *Robot Modelling and Control*, Wiley, 2001.
- [7] Daiki Ito, *Robot Vision*, Nova Publisher, 2009.
- [8] Budiharto W., Santoso A., Purwanto D., Jazidie A., *A Navigation System for Service robot using Stereo Vision*, International conference on Control, Automation and Systems, Korea, pp 101-107, 2011.
- [9] Hutchinson S., Hager G., Corke P., *A tutorial on visual servo control*, IEEE Trans. On Robotics and Automation, vol. 12(5), pp. 651-670, 1996.
- [10] Budiharto W., Purwanto D., Jazidie A., *A Robust Obstacle Avoidance for Service Robot using Bayesian Approach*, International Journal of Advanced Robotic Systems, Intech publisher, vol 8(1), 2011.
- [11] Budiharto, W., *The framework of Intelligent telepresence robot based on stereo vision*, Journal of Computer Science, vol. 8, pp. 2062-2067, 2012.
- [12] Okada K., et.al, Walking Navigation System of Humanoid Robot using Stereo Vision based Floor Recognition and Path Planning with Multi-Layered Body Image, Proceedings of the 2003 IEEE International Conference on Intelligent Robots and System, Nevada, 2003.